



INTERNATIONAL APPLICATION PUBLISHED UNDER THE PATENT COOPERATION TREATY (PCT)

<p>(51) International Patent Classification ⁷ : G01N 33/487, A61B 5/145</p>	<p>A1</p>	<p>(11) International Publication Number: WO 00/54047 (43) International Publication Date: 14 September 2000 (14.09.00)</p>
--	-----------	---

<p>(21) International Application Number: PCT/US00/06171 (22) International Filing Date: 9 March 2000 (09.03.00) (30) Priority Data: 09/267,179 12 March 1999 (12.03.99) US (71) Applicant: INTEG, INC. [US/US]; 2800 Patton Road, St. Paul, MN 55113 (US). (72) Inventors: ALLEN, John, J.; 1020 Brompton Place, Mendota Heights, MN 55188 (US). RACCHINI, Joel, R.; 4221 W. 44th Street, Edina, MN 55424 (US). (74) Agent: BRUESS, Steven, C.; Merchant & Gould P.C., P.O. Box 2903, Minneapolis, MN 55402-0903 (US).</p>	<p>(81) Designated States: AE, AL, AM, AT, AT (Utility model), AU, AZ, BA, BB, BG, BR, BY, CA, CH, CN, CR, CU, CZ, CZ (Utility model), DE, DE (Utility model), DK, DK (Utility model), DM, DZ, EE, EE (Utility model), ES, FI, FI (Utility model), GB, GD, GE, GH, GM, HR, HU, ID, IL, IN, IS, JP, KE, KG, KP, KR, KR (Utility model), KZ, LC, LK, LR, LS, LT, LU, LV, MA, MD, MG, MK, MN, MW, MX, NO, NZ, PL, PT, RO, RU, SD, SE, SG, SI, SK, SK (Utility model), SL, TJ, TM, TR, TT, TZ, UA, UG, UZ, VN, YU, ZA, ZW, ARIPO patent (GH, GM, KE, LS, MW, SD, SL, SZ, TZ, UG, ZW), Eurasian patent (AM, AZ, BY, KG, KZ, MD, RU, TJ, TM), European patent (AT, BE, CH, CY, DE, DK, ES, FI, FR, GB, GR, IE, IT, LU, MC, NL, PT, SE), OAPI patent (BF, BJ, CF, CG, CI, CM, GA, GN, GW, ML, MR, NE, SN, TD, TG).</p> <p>Published With international search report. Before the expiration of the time limit for amending the claims and to be republished in the event of the receipt of amendments.</p>
---	---

(54) Title: COLLECTION WELL FOR BODY FLUID TESTER

(57) Abstract
A body fluid is collected for testing for an analyte contained within the body fluid. The fluid is collected in an apparatus (10) including a reservoir (30) for receiving and collecting a flow of body fluid from a discharge end (24) of a conduit (20). A capillary test space is in fluid flow communication with the reservoir (30). The capillary test space (48) is sized to wick the fluid from the reservoir (30) when the fluid contacts the capillary test space.

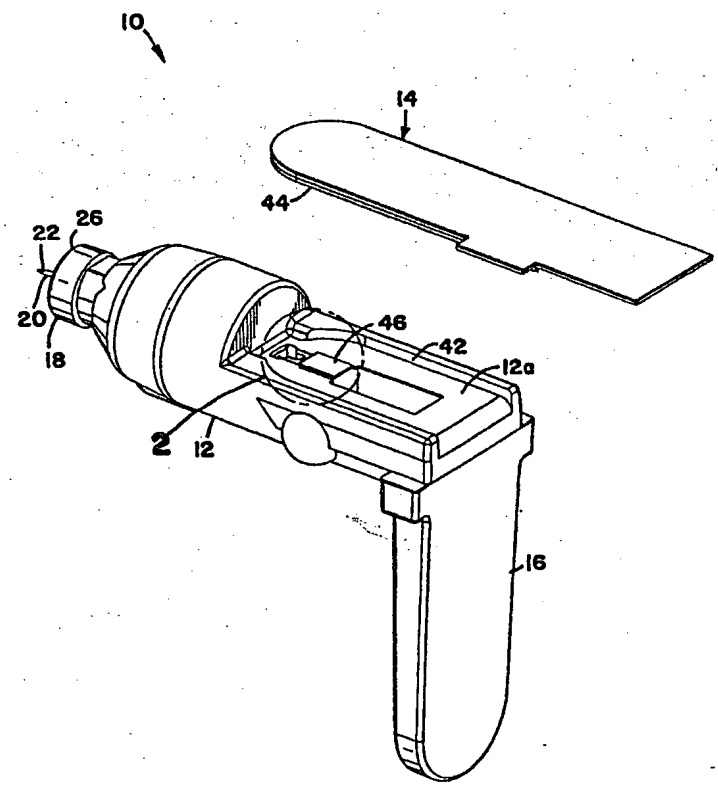

BEST AVAILABLE COPY

FOR THE PURPOSES OF INFORMATION ONLY

Codes used to identify States party to the PCT on the front pages of pamphlets publishing international applications under the PCT.

AL	Albania	ES	Spain	LS	Lesotho	SI	Slovenia
AM	Armenia	FI	Finland	LT	Lithuania	SK	Slovakia
AT	Austria	FR	France	LU	Luxembourg	SN	Senegal
AU	Australia	GA	Gabon	LV	Latvia	SZ	Swaziland
AZ	Azerbaijan	GB	United Kingdom	MC	Monaco	TD	Chad
BA	Bosnia and Herzegovina	GE	Georgia	MD	Republic of Moldova	TG	Togo
BB	Barbados	GH	Ghana	MG	Madagascar	TJ	Tajikistan
BE	Belgium	GN	Guinea	MK	The former Yugoslav Republic of Macedonia	TM	Turkmenistan
BF	Burkina Faso	GR	Greece	ML	Mali	TR	Turkey
BG	Bulgaria	HU	Hungary	MN	Mongolia	TT	Trinidad and Tobago
BJ	Benin	IE	Ireland	MR	Mauritania	UA	Ukraine
BR	Brazil	IL	Israel	MW	Malawi	UG	Uganda
BY	Belarus	IS	Iceland	MX	Mexico	US	United States of America
CA	Canada	IT	Italy	NE	Niger	UZ	Uzbekistan
CF	Central African Republic	JP	Japan	NL	Netherlands	VN	Viet Nam
CG	Congo	KE	Kenya	NO	Norway	YU	Yugoslavia
CH	Switzerland	KG	Kyrgyzstan	NZ	New Zealand	ZW	Zimbabwe
CI	Côte d'Ivoire	KP	Democratic People's Republic of Korea	PL	Poland		
CM	Cameroon	KR	Republic of Korea	PT	Portugal		
CN	China	KZ	Kazakstan	RO	Romania		
CU	Cuba	LC	Saint Lucia	RU	Russian Federation		
CZ	Czech Republic	LI	Liechtenstein	SD	Sudan		
DE	Germany	LK	Sri Lanka	SE	Sweden		
DK	Denmark	LR	Liberia	SG	Singapore		
EE	Estonia						



INTERNATIONAL APPLICATION PUBLISHED UNDER THE PATENT COOPERATION TREATY (PCT)

<p>(51) International Patent Classification 7 : G01N 33/487, A61B 5/145</p>	<p>A1</p>	<p>(11) International Publication Number: WO 00/54047 (43) International Publication Date: 14 September 2000 (14.09.00)</p>
<p>(21) International Application Number: PCT/US00/06171 (22) International Filing Date: 9 March 2000 (09.03.00) (30) Priority Data: 09/267,179 12 March 1999 (12.03.99) US (71) Applicant: INTEG, INC. [US/US]; 2800 Patton Road, St. Paul, MN 55113 (US). (72) Inventors: ALLEN, John, J.; 1020 Brompton Place, Mendota Heights, MN 55188 (US). RACCHINI, Joel, R.; 4221 W. 44th Street, Edina, MN 55424 (US). (74) Agent: BRUESS, Steven, C.; Merchant & Gould P.C., P.O. Box 2903, Minneapolis, MN 55402-0903 (US).</p>		<p>(81) Designated States: AE, AL, AM, AT, AT (Utility model), AU, AZ, BA, BB, BG, BR, BY, CA, CH, CN, CR, CU, CZ, CZ (Utility model), DE, DE (Utility model), DK, DK (Utility model), DM, DZ, EE, EE (Utility model), ES, FI, FI (Utility model), GB, GD, GE, GH, GM, HR, HU, ID, IL, IN, IS, JP, KE, KG, KP, KR, KR (Utility model), KZ, LC, LK, LR, LS, LT, LU, LV, MA, MD, MG, MK, MN, MW, MX, NO, NZ, PL, PT, RO, RU, SD, SE, SG, SI, SK, SK (Utility model), SL, TJ, TM, TR, TT, TZ, UA, UG, UZ, VN, YU, ZA, ZW, ARIPO patent (GH, GM, KE, LS, MW, SD, SL, SZ, TZ, UG, ZW), Eurasian patent (AM, AZ, BY, KG, KZ, MD, RU, TJ, TM), European patent (AT, BE, CH, CY, DE, DK, ES, FI, FR, GB, GR, IE, IT, LU, MC, NL, PT, SE), OAPI patent (BF, BJ, CF, CG, CI, CM, GA, GN, GW, ML, MR, NE, SN, TD, TG).</p> <p>Published <i>With international search report. Before the expiration of the time limit for amending the claims and to be republished in the event of the receipt of amendments.</i></p>

(54) Title: COLLECTION WELL FOR BODY FLUID TESTER

(57) Abstract

A body fluid is collected for testing for an analyte contained within the body fluid. The fluid is collected in an apparatus (10) including a reservoir (30) for receiving and collecting a flow of body fluid from a discharge end (24) of a conduit (20). A capillary test space is in fluid flow communication with the reservoir (30). The capillary test space (48) is sized to wick the fluid from the reservoir (30) when the fluid contacts the capillary test space.

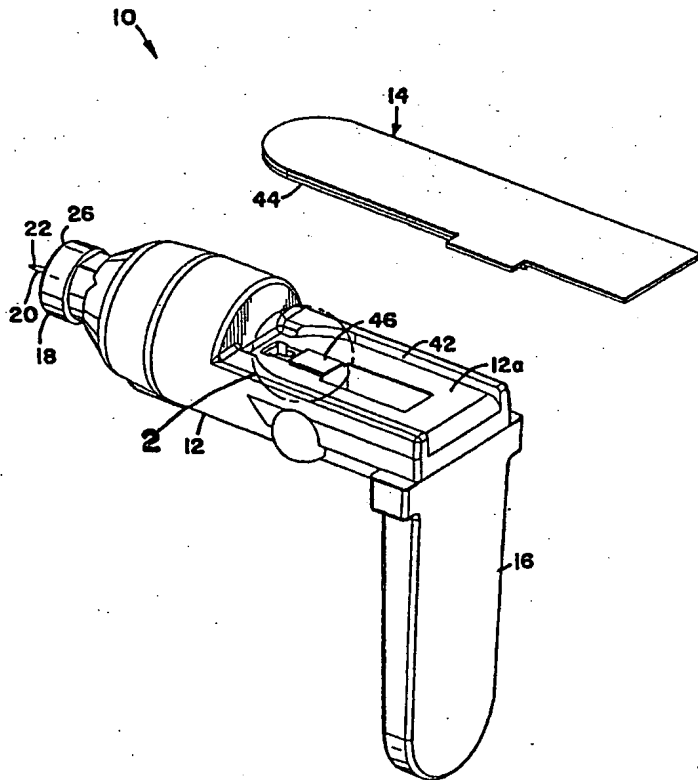

FOR THE PURPOSES OF INFORMATION ONLY

Codes used to identify States party to the PCT on the front pages of pamphlets publishing international applications under the PCT.

AL	Albania	ES	Spain	LS	Lesotho	SI	Slovenia
AM	Armenia	FI	Finland	LT	Lithuania	SK	Slovakia
AT	Austria	FR	France	LU	Luxembourg	SN	Senegal
AU	Australia	GA	Gabon	LV	Latvia	SZ	Swaziland
AZ	Azerbaijan	GB	United Kingdom	MC	Monaco	TD	Chad
BA	Bosnia and Herzegovina	GE	Georgia	MD	Republic of Moldova	TG	Togo
BB	Barbados	GH	Ghana	MG	Madagascar	TJ	Tajikistan
BE	Belgium	GN	Guinea	MK	The former Yugoslav Republic of Macedonia	TM	Turkmenistan
BF	Burkina Faso	GR	Greece	ML	Mali	TR	Turkey
BG	Bulgaria	HU	Hungary	MN	Mongolia	TT	Trinidad and Tobago
BJ	Benin	IE	Ireland	MR	Mauritania	UA	Ukraine
BR	Brazil	IL	Israel	MW	Malawi	UG	Uganda
BY	Belarus	IS	Iceland	MX	Mexico	US	United States of America
CA	Canada	IT	Italy	NE	Niger	UZ	Uzbekistan
CF	Central African Republic	JP	Japan	NL	Netherlands	VN	Viet Nam
CG	Congo	KE	Kenya	NO	Norway	YU	Yugoslavia
CH	Switzerland	KG	Kyrgyzstan	NZ	New Zealand	ZW	Zimbabwe
CI	Côte d'Ivoire	KP	Democratic People's Republic of Korea	PL	Poland		
CM	Cameroon	KR	Republic of Korea	PT	Portugal		
CN	China	KZ	Kazakstan	RO	Romania		
CU	Cuba	LC	Saint Lucia	RU	Russian Federation		
CZ	Czech Republic	LI	Liechtenstein	SD	Sudan		
DE	Germany	LK	Sri Lanka	SE	Sweden		
DK	Denmark	LR	Liberia	SG	Singapore		
EE	Estonia						

COLLECTION WELL FOR BODY FLUID TESTER**TECHNICAL FIELD**

This invention pertains to testing a body fluid for an analyte. For example,
5 the present invention is applicable for testing glucose in a body fluid such as blood
or interstitial fluid.

BACKGROUND

Numerous patents teach various ways for collecting a sample of body fluid
10 and testing such fluid for an analyte such as glucose. For example, United States
Patents 5,823,973 and 5,820,570 describe methods and apparatus for obtaining, in
one embodiment, interstitial fluid, which is tested for glucose through IR absorption.
These patents also describe use of the disclosed inventions in colorimetric and
electro-chemical testing of glucose. U.S. Pat. No. 5,453,360 teaches a test strip for
15 colorimetric testing for glucose. Blood is placed on a test strip containing various
chemical components including a dye. The degree of color change of the test strip
indicates the amount of glucose. United States Patents 5,508,171 and 5,628,890
teach electro-chemical testing. Blood is placed on a test strip containing electrodes.
Reaction of glucose on the electrodes generates a current indicating the amount of
20 glucose present in the blood.

Present development efforts are directed to testing very small volumes of
body fluid (e.g. about 0.5 microliter). The use of such small volumes of fluid
permits less painful collection of a fluid samples. However, small fluid volumes
present additional challenges for analyte testing. For example, testing for analytes
25 typically requires a fluid sample in excess of a predetermined minimum volume. By
way of non-limiting representative example, a test may require a minimum sample
size of 5 microliter to yield reliable test results.

Furthermore, sample collection systems may receive a flow of body fluid
over an extended time (e.g., 10 seconds or more) before a minimum sample volume
30 is collected. As a result, body fluid may be deposited on test components (e.g.,
electrodes or colorimetric test strips) before a full sample is collected. Such
premature deposit may initiate chemical reactions on a test strip thereby consuming

reagents before a reliable test can be initiated. Further, such test components may be coupled to logic circuits for calculating an analyte's concentration based on readings from the test strip. A premature deposit of an inadequate volume of fluid sample may falsely inform logic circuits that testing has initiated when, in fact, an adequate
5 sample volume has yet to be collected.

Recognizing the problems of premature test initiation, the prior art has developed techniques for delaying test initiation until an adequate volume of sample is collected. For example, logic circuits may have a built-in time delay which assumes a fixed period of time to collect an adequate volume of sample. Of course,
10 such systems suffer from the fact there is no certainty that an adequate volume is collected during such time delay. Alternatively, to be conservative, such time delays may frequently be unnecessarily long. Additionally, United States Patent 5,049,487 teaches reading a reflectance of a side of a membrane. A fluid sample is placed on the opposite side. When the sample is absorbed through the membrane,
15 the change in reflectance is noted indicating testing may commence. However, such a system suffers from chemical agents on the membrane being in contact with a sample prior to initiating testing.

Therefore, there is a need for a method and apparatus for collecting a sample of body fluid to obtain an adequate volume of such fluid.

20

SUMMARY

According to a preferred embodiment of the present invention, a method and apparatus are disclosed for collecting a body fluid for testing for an analyte contained within the body fluid. The apparatus includes a reservoir for receiving and
25 collecting a flow of body fluid from a discharge end of a conduit. A capillary test space is in fluid flow communication with the reservoir. The capillary test space is positioned to be in contact with the fluid in the reservoir after the fluid has accumulated to a predetermined transfer volume of fluid. The capillary test space is sized to wick the fluid from the reservoir when the fluid contacts the entrance end.
30 With the present invention, fluid is collected within the reservoir at a rate of flow limited by the conduit. When the reservoir is full, the collected fluid rapidly wicks

into the capillary test space. The capillary test space may contain test components for testing for the analyte.

BRIEF DESCRIPTION OF THE DRAWINGS

- 5 Fig. 1 is a perspective view of a sample collection apparatus with an electro-chemical test strip shown removed;
- Fig. 2 is an enlarged segmented view of the area of circle 2 in Fig. 1;
- Fig. 3 is a side-sectional view of the apparatus of Fig. 1 showing the test strip in place;
- 10 Fig. 4 is an enlarged segmented view of the area of circle 4 in Fig. 3;
- Fig. 5 is a segmented top-plan view of a reservoir of the apparatus of Fig. 1;
- Fig. 6 is a view taken along line 6-6 in Fig. 3 and showing a bolus of body fluid residing in a capillary test space;
- Fig. 7 is a top plan view of a first alternative embodiment of the present
- 15 invention;
- Fig. 8 is a view taken along line 8 - 8 of Fig. 7;
- Fig. 9 is a view similar to Fig. 8 showing a second alternative embodiment of the present invention;
- Fig. 10 is a view similar to those of Figs. 8 and 9 showing a third alternative
- 20 embodiment of the present invention;
- Fig. 11 is a top plan view of the embodiment of Fig. 10 with a test strip removed; and
- Fig. 12 is a view similar to Fig. 11 showing a fourth alternative embodiment
- 25 of the present invention

DETAILED DESCRIPTION

With reference to the various drawing figures in which identical elements are numbered identically throughout, a description of a preferred embodiment will now be provided. Throughout this description, the present invention will be described

30 with reference to collecting a sample of interstitial fluid for glucose testing using a narrow needle that penetrates into, but not through, the dermis as more fully described in commonly assigned United States Patents 5,823,973 and 5,820,570, the

disclosures for both of which are hereby incorporated herein by reference. While such a use is a preferred embodiment, the present invention is applicable to other fluid collection systems (e.g., blood collection) as well as testing for other fluid analytes. Further, the present invention is described with reference to using electro-chemical testing of a collected sample. The teachings of the present invention are
5 equally applicable to other testing methods such as colormetric testing and IR absorption testing.

Referring now to Figures 1-6, a collection apparatus 10 includes a main body 12 and a test strip 14. The main body has a handle 16 and a needle-containing
10 ferrule 18. The ferrule 18 holds a hollow needle 20 extending from a penetration end 22 to a discharge end 24. The penetration end 22 protrudes from a radially spaced ring end 26 of the ferrule 18.

In a preferred embodiment, the penetration end 22 is axially spaced from ring end 26 by a distance sufficient for the needle 20 to penetrate into but not through a
15 patient's dermis to collect a sample of substantially blood-free interstitial fluid as taught in United States Patent 5,820,570. In such an embodiment, the outer diameter of the needle is about .013 inch (about 0.33 mm). This sizing of the needle permits substantially pain-free penetration of the needle to collect a body fluid. This description illustrates a preferred embodiment. Needle 20 may be sized to collect
20 any body fluid such as blood or interstitial fluid. Further, the present invention is disclosed where the skin penetration member (i.e., the needle 20) also serves as a conduit for supplying fluid to a reservoir 30 as will be described. The present invention is also applicable to any conduit for transporting a body fluid (e.g., a capillary tube as described in International Application PCT/US97/08400 published
25 November 20, 1997 as International Publication No. WO 97/42883).

The test strip 14 contains exposed test components on an inner surface 14a. The test components are shown in the form of electrodes 32 for testing a body fluid for an analyte such as glucose through electro-chemical testing. As previously described, the test components could be components for alternate testing techniques
30 such as colormetric or IR absorption testing.

Not shown is a housing for holding the apparatus 10 during sample collection and testing. Housings for holding disposable body fluid samplers are

shown in United States Patent 5,823,973. Such housings may contain electrical components for electrical connection to the test strip electrodes 32 to connect a signal from the electrodes 32 to logic circuits to compute and report on the analyte in response to signals from the electrodes 32 during testing.

5 The material of the main body 12 defines a cylindrical reservoir 30 having a cylindrical axis between a first end 34 and a second end 36. In the embodiment shown, the axis of the reservoir 30 is perpendicular to the axis of the needle 20. Such a relative alignment is not necessary for adequate function and any other alignment is acceptable.

10 The reservoir 30 has a volume at least as great as a desired test volume of body fluid to be tested. In a preferred embodiment, reservoir 30 has a volume of 0.7 microliters. As will become apparent, fluid is collected in the reservoir 30 and accumulates with a fluid level rising from the first end 34 toward the second end 36. Due to such small volumes and the geometry of reservoir 30, surface tension assures
15 the fluid is retained in the reservoir 30 with the fluid level rising as described regardless of the orientation of the apparatus 10 (i.e., the operation of the apparatus 10 is gravity independent).

 The discharge end 24 of the needle 20 is disposed within the reservoir 30 adjacent the first end 34. Accordingly, body fluid is transported from the
20 penetration end 22, through needle 20 and discharged from the discharge end 24 into the reservoir 30 at the first end 34.

 The material of the body 12 also defines an enlarged empty volume 38 positioned between the reservoir 30 and the ferrule 18 and surrounding the needle 20. The enlarged volume 38 is separated from the reservoir 30 by material of the
25 main body pinching against the needle 20 as at locations 40. The enlarged volume 38 has a volume larger than the reservoir 30 and ensures that fluid within the reservoir 30 is retained within reservoir 30 as it accumulates. For example, in the absence of enlarged volume 38, manufacturing tolerances may result in a narrow spacing between the material of main body 12 and needle 20. Such a narrow
30 spacing could function as a capillary space communicating with reservoir 30 which would wick fluid out of reservoir 30. The enlarged volume 38 precludes such capillary wicking. Further, the material defining the volume 38 is preferably

hydrophobic to minimize wicking. In the event precise manufacturing permits complete liquid-tight sealing around needle 20, the enlarged volume 38 could be eliminated.

5 The test strip 14 is secured to the main body (e.g., through adhesives) with the inner surface 14a facing the main body 12 and overlying the second end 36 of the reservoir 30. The main body 12 includes a groove 42 shaped complementary to the outer periphery of the test strip 14 to ensure accurate alignment of the test strip 14 with the main body 12. Adjacent its outer periphery, the inner surface 14a of the test strip 14 includes spacers 44 (shown best in Fig. 6). The spacers 44 insure
10 uniform and close parallel spacing of the inner surface 14a from a test strip opposing surface 12a of the main body 12 for reasons that will become apparent. Alternatively, spacers could be formed on the body 12 thereby eliminating the need for spacers 44.

The test strip opposing surface 12a includes a step 46. With reference to Fig.
15 6, the construction described above results in formation of a capillary test space 48 defined between opposing surfaces of the test strip inner surface 14a and step 46.

As shown in Fig. 6, the spacers 44 are spaced from opposing surfaces of the step 46 thereby defining enlarged volumes 50 on opposite sides of the step 46. The enlarged volumes 50 perform a function similar to that of enlarged volume 38.
20 Namely, if the spacers 44 were sized to abut step 46, small capillary spaces could form between the spacers 44 and step 46. Such capillary spaces could wick fluid from the fluid receiving volume 48. Again, if manufacturing could ensure a fluid-tight seal between spacers 44 and step 46, the volumes 50 could be eliminated.

Shown best in Figs. 4 and 6, the electrodes 32 are positioned opposing the
25 step 46. Further, the spacing S (Fig. 4) between the step 46 and inner surface 14a is uniform and is selected to be sufficiently narrow for the capillary test space 48 to act as a capillary space to wick fluid from the reservoir 30. An entrance end 52 of the capillary test space 48 is positioned at the second end 36 of the reservoir 30 (Fig. 4). The preferred spacing S is about .003 -- .005 inch (about .075 mm to .125 mm).
30 The spacing S may be as large as .012 inch (about .300 mm) or larger depending on the surface tension and volume of the fluid being collected and the relative hydrophobic/hydrophilic characteristics of the main body 12 and test strip 14.

A hole 54 is formed through the body 12 and into the fluid receiving volume 48 on a side of the step 46 opposite the reservoir 30. The hole 54 permits air in the capillary test space 48 to be vented to atmosphere as fluid flows into the capillary test space 48 from the reservoir 30. Volumes 50 also provide venting.

5 An additional advantage of this embodiment is its ability to minimize the effects of sample concentration via evaporation. The total air volume contained within the enclosed sections substantially defined by volume 38, reservoir 30, the capillary test space 48, and adjoining volumes spaces, is sufficiently small so as to provide a very low capacity for evaporation of water from the aqueous sample being
10 collected. In addition, the location of the vent and the overall geometry discourage convective passage of air through the aforementioned spaces, minimizing any convective acceleration of evaporation. When dealing with small volumes (e.g. less than 1 microliter), minimizing evaporative losses can be important to maintaining the integrity of the sample for quantitative analysis.

15 With the construction thus described, the apparatus 10 is used by urging the ring end 26 against a patient's skin. The penetration tip 22 penetrates the skin. The ring end 26 (being radially spaced from tip 22) acts to urge fluid into the needle 20. The fluid flows along the needle 20 and discharges into the first end 34 of the reservoir 30 through discharge end 24. In one possible embodiment, suction could
20 be applied to advance the rate of flow of fluid through needle 20. Suction is not used in other embodiments.

Fluid accumulates in the reservoir 30 with a level of accumulated fluid growing from the first end 34 to the second end 36. When the fluid level reaches the second end 36, a desired volume of fluid to be tested has accumulated in the
25 reservoir 30. At this time, the fluid level contacts the entrance end 52 of the capillary test space 48. Since the capillary test space 48 is a narrow capillary space, the fluid is rapidly wicked out of the reservoir 30 and into the capillary test space 48 as a bolus delivery of fluid indicated by the bolus of fluid 56 in Fig. 6. So positioned, the fluid is in contact with the electrodes 32 and testing of the fluid may
30 commence.

The present invention permits fluid contact with the electrodes 32 only after an adequate volume of fluid has been collected. By way of non-limiting

representative example, it may take thirty seconds for fluid to fill the reservoir 30 and only one second for the accumulated fluid to be wicked into the capillary test space 48 from the reservoir 30. As a result, the present invention avoids a long period of time during which fluid is contacting the electrodes 32 and before testing may commence. Further, without the need for specialized electronics as used in the prior art, testing cannot commence until after an adequate volume of fluid has been accumulated. Therefore, when a signal is received from electrodes 32, it is known that an adequate volume of fluid is opposing the electrodes 32.

The retention of fluid in the reservoir 30 and wicking of fluid into the capillary test space 48 can be controlled and modified by varying the dimensions of the components as will be apparent to one of ordinary skill in the art having the benefit of the teachings of the present invention. Further, as will be apparent to such artisan, such retention and wicking may also be controlled and modified through material selection. For example, it is desirable that the main body 12 be formed of hydrophobic material and that the capillary test space 48 be more hydrophilic. For example, a hydrophilic surfactant may be applied to step 46 or test strip inner surface 14a (or both) to make the capillary test space 48 more hydrophilic than the reservoir 30.

It may be desirable to have one of electrodes 32 completely wetted with fluid from reservoir 30 before the other of the electrodes 30 is wetted. Figs. 7 - 12 illustrate several alternative embodiments for achieving such sequential wetting. In the embodiments, elements in common with those already described are numbered identically with the addition of letter suffices (i.e., "a", "b", "c" and "d"). Such elements are not separately described unless modified by the alternative embodiment.

In Figs. 7 and 8, it is desirable to completely wet electrode 32a before wetting electrode 32a'. The electrodes 32a, 32a' are positioned side-by-side on test strip 14a and equidistant from reservoir 30a. As shown in Fig. 8, the step 46 of the previously described embodiment is divided into two steps 46a, 46a' opposing respective ones of electrodes 32a, 32a'. A hydrophobic volume 50a' is positioned between the steps 46a, 46a'. The volume 50a' functions similarly to side volumes 50a (and 50 in the embodiment of Fig. 6) to act as a hydrophobic barrier to prevent

fluid from flowing between the steps 46a, 46a'. The steps 46a, 46a' are spaced from test strip 14 by spaces Sa and Sa'. Since space Sa is smaller than space Sa', fluid first flows from reservoir 30a into space Sa before flowing from reservoir 30a into space Sa'.

5 In the embodiment of Fig. 9, fluid is inclined to first flow onto step 46b before onto step 46b'. However, in Fig. 9, the volume barrier 50a' of Fig. 8 has been replaced with a ramp surface 47b connecting steps 46b and 46b'. Therefore, fluid can flow from space Sb to space Sb' after space Sb has first filled with fluid.

10 In the embodiment of Figs. 10 and 11, the steps 46c, 46c' are positioned on opposite sides of the reservoir 30c. If spaces Sc and Sc' are equal, fluid flows simultaneously into the spaces Sc and Sc' but does not flow between the spaces Sc and Sc'. The spaces Sc and Sc' may be varied to change the rate of flow into the spaces Sc and Sc'.

15 The embodiment of Fig. 12 is similar to that of Fig. 9. Instead of the ramp 47b of Fig. 9 (which connects steps 46b and 46b' directly across a side-to-side path), the ramp 47d is U-shaped for fluid to flow from step 46d to step 46d' in a U-shaped path A on a side of the steps 46d, 46d' opposite the reservoir 30d.

20 From the foregoing detailed description, the present invention has been described in a preferred embodiment. Modifications and equivalents of such disclosure are intended to be included in the appended claims. For example, either or both of the reservoir 30 and capillary test space 48 need not be an empty volume but could be filled with an absorbent material.

The Claimed Invention Is:

1. An apparatus for collecting a body fluid for testing for an analyte contained within said body fluid, said apparatus comprising:
 - a reservoir for receiving and collecting a flow of body fluid from a discharge end
5 of a conduit;
 - a capillary test space positioned to be in contact with said fluid in said reservoir after said fluid has accumulated within said reservoir to a transfer volume of fluid; and
 - said capillary test space sized to wick said fluid from said reservoir when said
10 fluid in said reservoir attains said transfer volume.

2. An apparatus according to claim 1 further comprising:
 - test components within said capillary test space for testing said fluid for said
15 analyte.

3. An apparatus according to claim 2 wherein:
 - said test components include electrodes for electro-chemically testing said fluid;
 - said electrodes positioned within said capillary test space to be in contact with
20 said fluid after said fluid is wicked into said capillary test space.

4. An apparatus according to claim 1 wherein:
 - said reservoir includes first and second spaced-apart ends;
 - said discharge end of said conduit disposed adjacent said first end; and
 - said capillary test space is disposed adjacent said second end.
25

5. An apparatus according to claim 4 wherein a volume of said reservoir between
said first and second ends of said reservoir is sized to be at least as great as said
transfer volume.

- 30 6. An apparatus according to claim 1 wherein said capillary test space is vented.

7. An apparatus according to claim 1 wherein material defining said capillary test space is more hydrophilic than material defining said reservoir.

8. An apparatus according to claim 1 wherein:
 - 5 said conduit is a needle extending from a penetration end to said discharge end; said needle penetration end being exposed for penetration into a patient's skin to access body fluid for said fluid to flow along said needle and discharged into said reservoir at said discharge end.

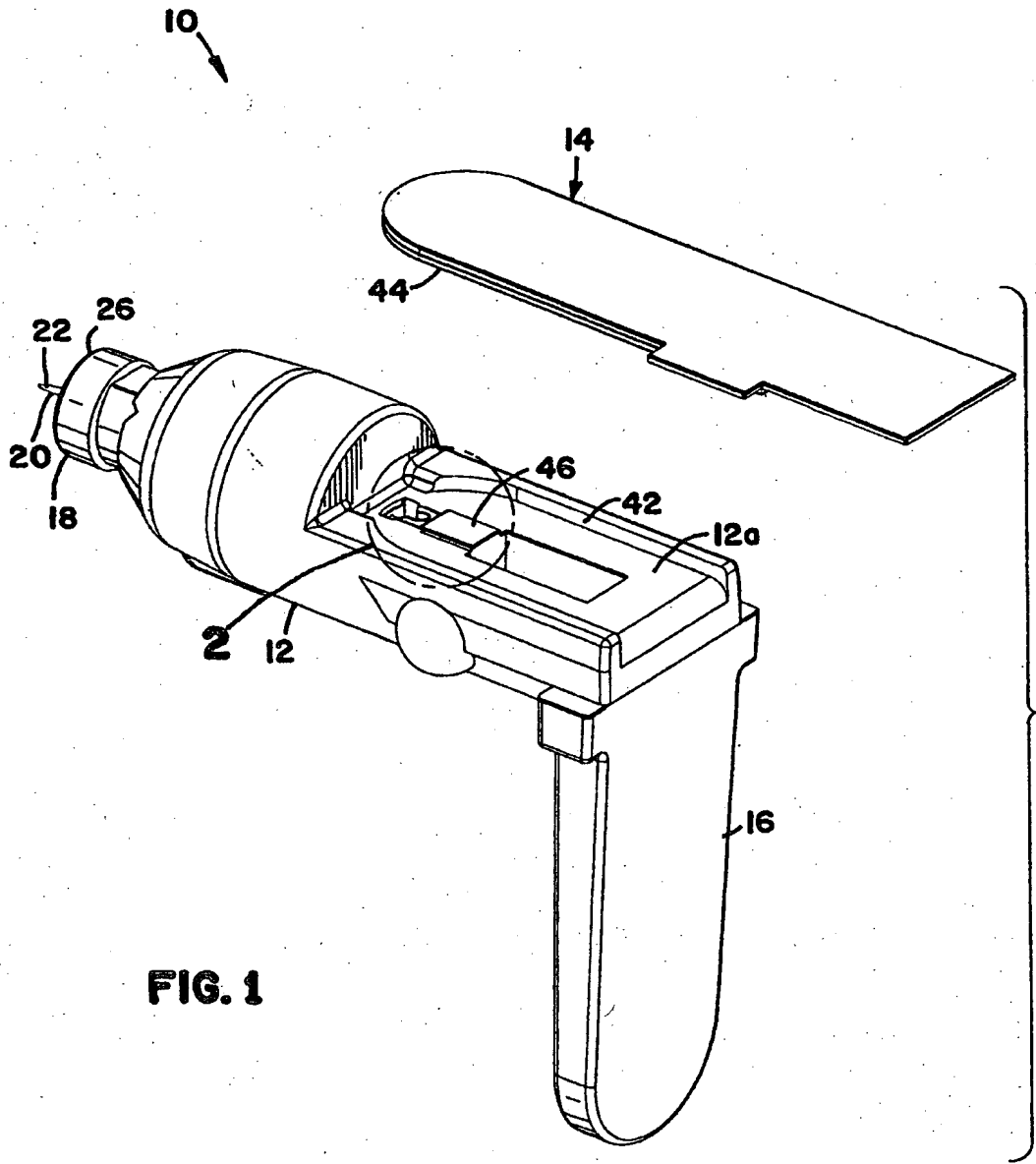

FIG. 1

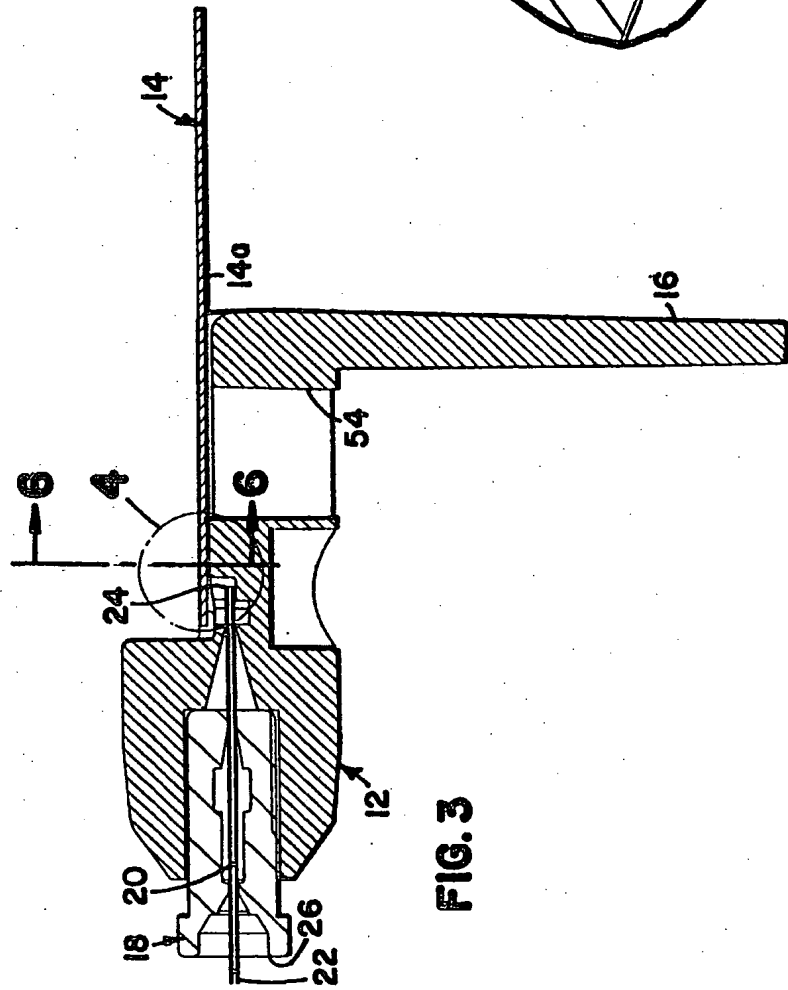

FIG. 3

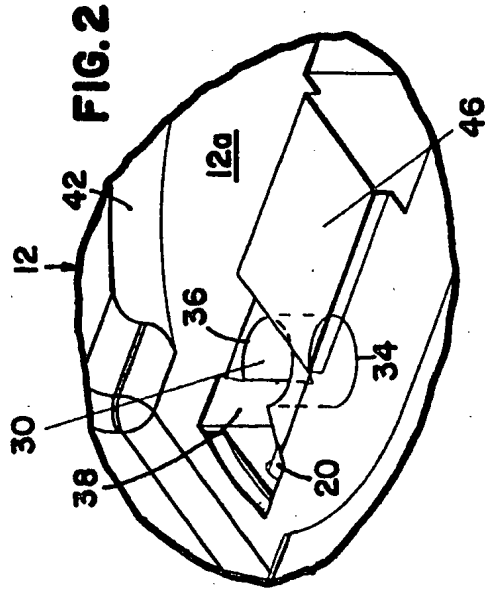

FIG. 2

FIG. 4

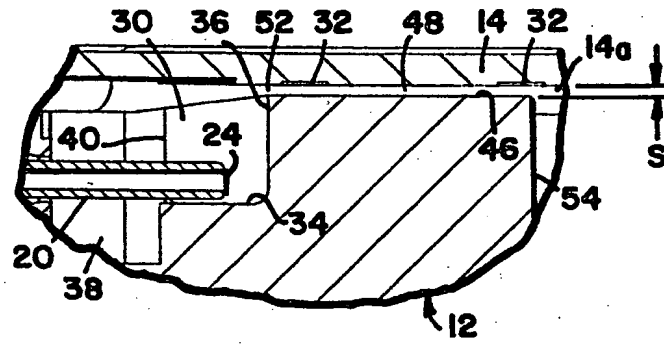

FIG. 5

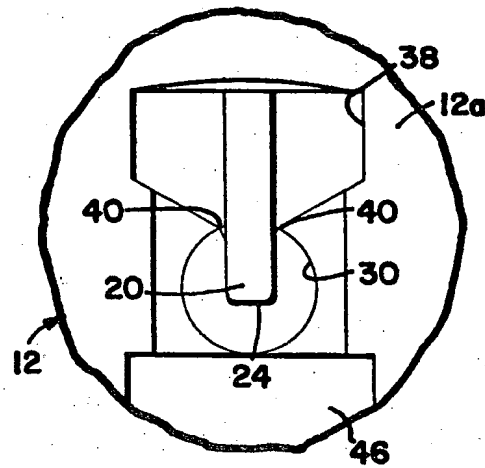

FIG. 6

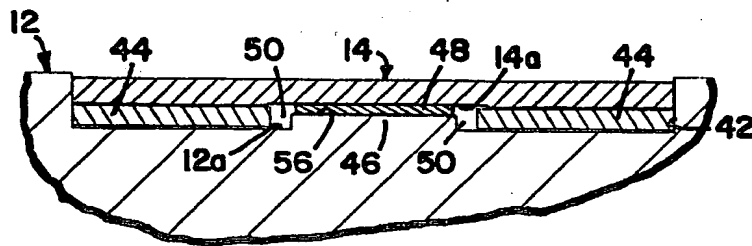

FIG. 7

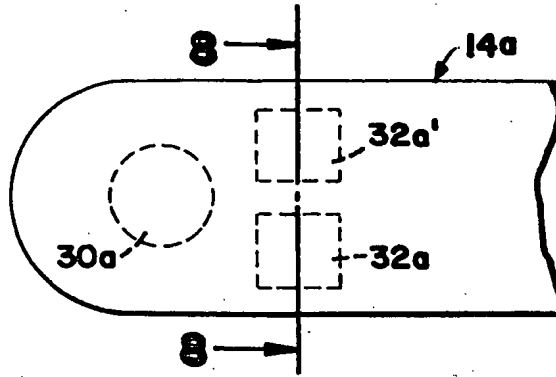

FIG. 8

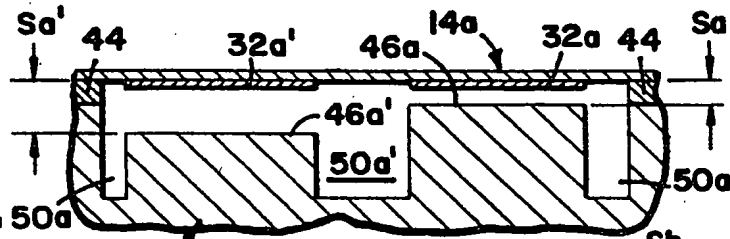

FIG. 9

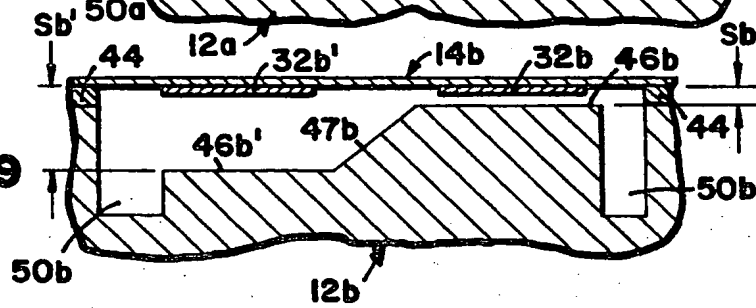

FIG. 10

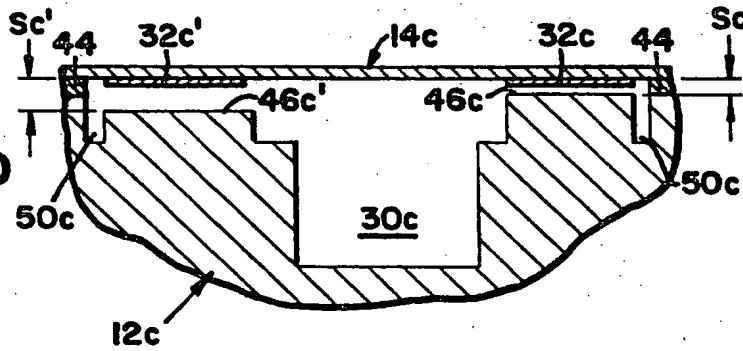

FIG.11

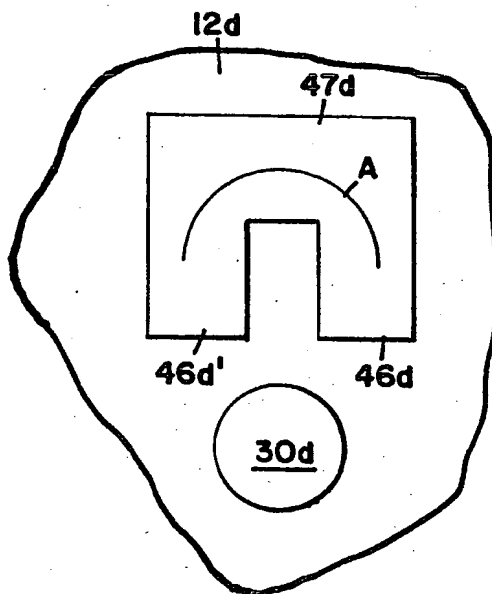
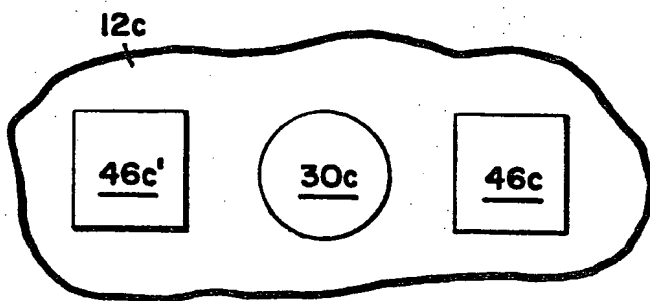

FIG.12

INTERNATIONAL SEARCH REPORT

Int. l. Application No

PCT/US 00/06171

A. CLASSIFICATION OF SUBJECT MATTER
 IPC 7 G01N33/487 A61B5/145

According to International Patent Classification (IPC) or to both national classification and IPC

B. FIELDS SEARCHED

Minimum documentation searched (classification system followed by classification symbols)
 IPC 7 G01N A61B

Documentation searched other than minimum documentation to the extent that such documents are included in the fields searched

Electronic data base consulted during the international search (name of data base and, where practical, search terms used)

EPO-Internal

C. DOCUMENTS CONSIDERED TO BE RELEVANT

Category *	Citation of document, with indication, where appropriate, of the relevant passages	Relevant to claim No.
X	EP 0 306 158 A (THORN EMI PLC) 8 March 1989 (1989-03-08) column 1, line 53 -column 2, line 40 -----	1-3
X	EP 0 396 016 A (SPACELABS, INC.) 7 November 1990 (1990-11-07) column 8, line 13 - line 34 column 9, line 30 - line 44 column 10, line 21 - line 33 -----	1,3,4,6, 8
X	WO 97 38126 A (MERCURY DIAGNOSTICS, INC.) 16 October 1997 (1997-10-16)	1,6
A	page 25, line 8 - line 28 page 27, line 6 -page 28, line 8 page 34, line 9 - line 17 -----	4

Further documents are listed in the continuation of box C.

Patent family members are listed in annex.

* Special categories of cited documents :

- "A" document defining the general state of the art which is not considered to be of particular relevance
- "E" earlier document but published on or after the international filing date
- "L" document which may throw doubts on priority claim(s) or which is cited to establish the publication date of another citation or other special reason (as specified)
- "O" document referring to an oral disclosure, use, exhibition or other means
- "P" document published prior to the international filing date but later than the priority date claimed

- "T" later document published after the international filing date or priority date and not in conflict with the application but cited to understand the principle or theory underlying the invention
- "X" document of particular relevance; the claimed invention cannot be considered novel or cannot be considered to involve an inventive step when the document is taken alone
- "Y" document of particular relevance; the claimed invention cannot be considered to involve an inventive step when the document is combined with one or more other such documents, such combination being obvious to a person skilled in the art.
- "&" document member of the same patent family

Date of the actual completion of the international search

Date of mailing of the international search report

3 August 2000

10/08/2000

Name and mailing address of the ISA
 European Patent Office, P.B. 5818 Patentaan 2
 NL - 2280 HV Rijswijk
 Tel. (+31-70) 340-2040, Tx. 31 651 epo nl,
 Fax: (+31-70) 340-3016

Authorized officer

Rieb, K.D.

INTERNATIONAL SEARCH REPORT

Information on patent family members

International Application No

PCT/US 00/06171

Patent document cited in search report	Publication date	Patent family member(s)	Publication date
EP 306158 A	08-03-1989	AT 94284 T	15-09-1993
		DE 3883895 D	14-10-1993
		DE 3883895 T	24-03-1994
		JP 1072049 A	16-03-1989
		JP 2829000 B	25-11-1998
		US 5064618 A	12-11-1991
EP 396016 A	07-11-1990	US 5145565 A	08-09-1992
		CA 2015287 A,C	01-11-1990
		JP 3063570 A	19-03-1991
WO 9738126 A	16-10-1997	US 5962215 A	05-10-1999
		AU 2608297 A	29-10-1997
		DE 19781096 T	17-12-1998
		DE 29723391 U	20-08-1998
		EP 0906447 A	07-04-1999
		GB 2322699 A	02-09-1998
		JP 11508693 T	27-07-1999

**This Page is Inserted by IFW Indexing and Scanning
Operations and is not part of the Official Record**

BEST AVAILABLE IMAGES

Defective images within this document are accurate representations of the original documents submitted by the applicant.

Defects in the images include but are not limited to the items checked:

- BLACK BORDERS**
- IMAGE CUT OFF AT TOP, BOTTOM OR SIDES**
- FADED TEXT OR DRAWING**
- BLURRED OR ILLEGIBLE TEXT OR DRAWING**
- SKEWED/SLANTED IMAGES**
- COLOR OR BLACK AND WHITE PHOTOGRAPHS**
- GRAY SCALE DOCUMENTS**
- LINES OR MARKS ON ORIGINAL DOCUMENT**
- REFERENCE(S) OR EXHIBIT(S) SUBMITTED ARE POOR QUALITY**
- OTHER:** _____

IMAGES ARE BEST AVAILABLE COPY.

As rescanning these documents will not correct the image problems checked, please do not report these problems to the IFW Image Problem Mailbox.

This Page Blank (uspto)